



Safe-Fly 2020 ADS-B Compliant GPS Module with Serial Data Combiner/Expander



Revision M
8/03/2018
GRTAvionics.com

Table of Contents

| | |
|--|----|
| Revision History | 3 |
| Description | 4 |
| Compatibility..... | 4 |
| Use with Non-Compatible GRT and other systems | 4 |
| GPS Function | 5 |
| Multiple GPS Configuration for your GRT EFIS | 5 |
| GPS Status Display (This section is preliminary) | 5 |
| Serial Data Combiner/Expander Function | 6 |
| Installation..... | 7 |
| Wiring | 7 |
| Power and Ground..... | 7 |
| Serial Ports | 8 |
| Safe-Fly/SPC Configuration | 8 |
| Default Configuration | 8 |
| Configuration Settings..... | 8 |
| Post-Installation Checkout Procedure | 9 |
| Status Reporting | 10 |
| GPS Specific Status..... | 10 |
| Approved Devices – Wiring and Configuration | 10 |
| Trig TT21/TT22 | 10 |
| Post-Installation Checkout - Verifying Trig TT-22 is Receiving GPS Data..... | 12 |
| Trig TT31 | 12 |
| Sandia | 13 |
| Uavionix | 13 |
| Specifications | 22 |
| Connector Pinout..... | 23 |
| Dimensions..... | 24 |
| Typical Wiring..... | 25 |
| Included Cable Assembly..... | 26 |

Revision History

Rev A – Initial Release 2/9/17

Rev B – Added description of supplied cable.

Rev C – Revised for timing output for hardware version RM-2020-02

Rev D – Added EchoUAT support. Revised wiring for SafeFly Rev B Hardware. Updated GPS status indicators.

Rev E – Added a section about recommended GPS configuration for with GRT EFIS.

Rev F – Various Changes

Rev G – Added wiring diagram and settings for Horizon and Sport WS and HS models with uAvionics EchoUAT.

Rev H – Added note to EchoUAT settings to remind user to enter aircraft specific information in the EchoUAT/TT22 settings menu on the general setup page.

Rev I – Minor clarifications of Uavionics EchoUAT wiring diagrams and applicability.

Rev J – Minor improvements for the Trig TT31. Added “Other TT31 Considerations” section.

Rev K – GPS Certification Level Setting changed to “B” for EchoUAT.

Rev L – Added minimum software versions for Trig TT22, settings for Flight ID and Address, GPS Certification level for Echo UAT is now A or B, VFR ID is now N-number

Rev M – Added clarification for each type of equipment supported to perform the Safe-Fly GPS/SPC configuration before performing the setup for the specific equipment.

Description

The Safe-Fly ADS-B compliant GPS module with serial data combiner provides GPS position data as a stand-alone module to various approved ADS-B out devices, or may be wired to any GRT EFIS to provide high integrity GPS position data, and provide more serial ports for all GRT EFIS display units except the WS and HS models. Included with the unit are a GPS antenna suitable for interior mounting, and mounting hardware.

Compatibility

The Safe-Fly GPS module is fully compatible with any GRT Mini, Sport SX, Horizon HX, ~~or~~ Horizon HxXr, Sport EX, or Horizon EX EFIS, and compatible with the Sport and Horizon WS and HS models as a GPS navigation source and for use with ADS-B in/out devices, but will not provide a serial combiner function for these models. It can also operate stand-alone with the ADS-B out devices listed in the “Approved Devices” section. The minimum software versions that support the module are:

| EFIS | Minimum Software Version |
|-------------------------|---------------------------------|
| All models of Mini EFIS | 3.00 |
| Sport EX/Horizon EX | 1.06 |
| Sport SX | 13.00 |
| HX | 9.00 |
| HXr | 5.01 |
| Sport or Horizon WS* | Any |
| Sport or Horizon HS* | Any |

* These units are not compatible with the serial data combiner and GPS accuracy indicator functions provided by the Safe-Fly GPS, nor can these units be used to configure the Safe-Fly GPS. The Safe-Fly may be ordered pre-configured as needed at no charge, allowing it provide GPS data to your ADS-B output device. In addition, a serial output from the Safe-Fly may be configured to provide NMEA0183 GPS data to these EFIS models.

Use with Non-Compatible GRT and other systems

The Safe-Fly GPS module can be used with non-compatible systems, and without any connection to an EFIS, with the following limitations:

- The module configuration cannot be changed, however the module can be ordered with its configuration set as desired at no additional cost.
- The integrity and accuracy data will not be indicated on the EFIS display unit.
- The serial combiner function cannot be used.

For these installations we do recommend using the NMEA0183 output to the EFIS, to provide the EFIS with a high-quality navigation source.

GPS Function

The Safe-Fly GPS Module utilizes a RAIM GPS which provides all data required for ADS-B 2020 compliance for ADS-B out devices listed in the “Approved Devices” section. The GPS data can also be used with any GRT EFIS, ~~except the WS display unit~~, to provide the EFIS with a high-integrity navigation source. The module communicates with compatible ADS-B out devices via a serial port connection, independent of the EFIS display unit.

Multiple GPS Configuration for your GRT EFIS

The high-integrity nature of this GPS position means the GRT EFIS user should configure the Safe-Fly GPS as one of the two possible GPS sources to the EFIS display unit, if at least one of the GPS inputs is not assigned to a panel mount GPS.

For installations without an external panel-mount GPS, configure the Safe-Fly GPS as GPS1 (or whichever GPS is commonly selected as the navigation source). For installations with one panel mount GPS that is approach capable, the Safe-Fly GPS should be used in lieu of a non-RAIM external GPS module.

Note that if your display unit includes an internal GPS, it is set as GPS1, GPS2, or NONE via the “Internal GPS” setting on the “General Setup” set menu. The internal GPS is a non-RAIM GPS in all EFIS display units equipped with an internal GPS.

GPS Status Display (This section is preliminary)

All GRT EFIS display units, with the exception of the Sport and Horizon HS/WS models, will show the integrity and accuracy of the GPS in the upper left corner of the screen. It should not be inferred that the “Approach” accuracy allows the GPS to be used for IFR approaches, however this indication is provided to enhance the understanding of the performance of their GPS installation. If GPS-INTEG is commonly displayed, or GPS-E or GPS-A is not observed, check the integrity of the antenna connection and location of the antenna.

GPS

No accuracy or integrity information is known about this GPS, or horizontal accuracy limit > 4 nm.

GPS-E

Valid position integrity and horizontal accuracy limit > 1.0 nm, and less than 4.0 nm, typical of IFR enroute requirements. *

GPS-A

Valid position integrity and horizontal accuracy limit > 0.3 nm and less than 1.0 nm, typical of IFR LNAV approach requirements. *

GPS-Integ

No Integrity – Insufficient data for validating data with RAIM integrity test. (Flashes Yellow and Green)

* The GPS and EFIS are not FAA certified.

Serial Data Combiner/Expander Function

In addition to the GPS functions, the module includes a serial port combiner function. The module includes 4 serial ports (input and output). One of these is dedicated for communication with ~~any~~ the EFIS display unit. The other 3 serial ports can be configured to send GPS data directly to an ADS-B output device, or used to expand the number of serial ports available to your display unit.

Recommended Usage of Serial Combiner/Expander Serial Ports

The design of the serial port combiner minimizes data latency (delays), however, connecting the following devices is not recommended due to their potential sensitivity to the additional latency.

- GRT Autopilot Servos
- Data to 3rd party autopilots, such as Trutrak and Trio
- AHRS, especially withwhen the system includes a connection to thean autopilots

Devices that provide large amounts of data at high baud rates (38400+), such as ADS-B receivers or XM weather will function through the combiner, but could exceed the capacity of the combiner and reduce the available data that could be passed through the other serial ports. For this reason, ~~if practical, it is preferred that~~ high- data rate devices must be wired directly to the display unit to avoid data loss.

Installation

Mounting holes are provided in the four corners of the case for #6 flat head screws. Two screws are sufficient when located in opposite corners for most installations. The module can be mounted in any orientation. Typically, the unit is mounted in the forward part of the airplane so its antenna can be positioned on the glare shield, and so it is near the GRT EFIS display units. The module should not be exposed to water, or in a location where it is likely to get wet, or where temperatures will exceed 150 deg F when in normal operation.

Wiring

The Safe-Fly GPS will operate with or without a connection to a GRT EFIS. In most cases it will be wired to a GRT EFIS to supply the EFIS with GPS data, and allow the use of the 3 serial ports on the module. (The serial data from these ports is combined into the one serial data stream to the EFIS, along with the GPS data, and transmitted to the EFIS via the Serial Control Out pin.) Typical wiring is illustrated at the end of this manual.

Power and Ground

Power – Power must be provided to at least one of the three power inputs on pins 23,24,25. +9-32VDC is required at 0.2A maximum. These inputs are isolated, and multiple power inputs can be used for redundancy.

Ground - One ground connection is recommended, to any of the provided ground pins.

GPS Backup Power – This connection is optional. It will draw about 30 uA from the aircraft battery, which is much smaller than the self-discharge rate of an aircraft battery. The GPS will acquire its position in less than 20 seconds when the GPS backup power connection is not used.

Serial Ports

When planning an installation, keep in mind that one serial output on the GPS module is required if the GPS is to provide data to an ADS-B out device. This connection minimizes latency, and allows GPS data to be sent to your ADS-B out device without dependence on a GRT EFIS that may be connected to it.

Control Port In/Out - This serial port is dedicated to use with a GRT EFIS. This connection allows the EFIS to change the configuration of the module's serial ports, and send and receive data from them.

Serial Ports 1,2,3 – These serial ports can be configured to transmit GPS data to an ADS-B output device. Ports 1 and 2 outputs are provided on two pins, and port 3 on three pins, so that “tee-ing” into an output when it is shared with more than one device is not required.

Safe-Fly/SPC Configuration

The module is shipped pre-configured in its default configuration. This configuration can be changed when the module is connected to a compatible GRT EFIS.

Default Configuration

The Safe-Fly GPS is shipped, configured to transmit NN33 on serial out 1, and NMEA0183 GPS data on serial out 2 and 3, plus RAIM integrity and accuracy data, as indicated in the following table:

| Serial Port | Default | Pins |
|-------------------|---------------------------------------|--------|
| Serial Port 1 Out | 38400 baud, Safe Fly NN33 | 19,20 |
| Serial Port 2 Out | 9600 baud, NMEA0183 + RAIM | 3,4 |
| Serial Port 3 Out | 4800 baud, NMEA0183 + RAIM | 1,2,15 |

The configuration of the module can be changed by connecting it to a compatible GRT EFIS. The configuration data is stored in the GPS module, allowing it to operate stand-alone after it is configured.

Configuration Settings

The EFIS display unit must be configured for this module when it is wired to one of its serial ports. Using the “Set Menu”, “General Setup”, configure the serial port on the EFIS that is wired to the “Serial Control Input/Output” as “Safe-Fly GPS and /SPC”, at 115,200 baud. After saving these settings, the General sSetup menu will show additional settings associated with this module. They appear just after the serial port configuration settings.

| Setting | Description |
|------------------------------|---|
| SPC Serial Port 1,2,3 Rate | Rate applies to input and output |
| SPC Serial Port 1,2,-3 Input | Functions available are the same as the EFIS, with the addition of multiple ADS-B GPS output function. |
| SPC Serial Port 1,2,3 Output | Functions available are the same as the EFIS, with the addition of <u>multiple ADS-B GPS output functions.</u> ADS-B specific data formats. |
| GRT Safe-Fly GPS | To use this GPS as a navigation source to the EFIS, set it to “GPS1”, or “GPS2”. If not used as a navigation source to the EFIS, set it to “Not Assigned”. Note that the EFIS supports 2 GPS inputs, and only one GPS input can be assigned to GPS1 or GPS2, so it may be necessary to change an internal GPS input to “Not Assigned”, or a serial input configured for GPS1 or GPS2 must be set to “Not Used”. |

Post-Installation Checkout Procedure

When used to provide position to an ADS-B out device, an ADS-B receiver can be used to verify position data is being received by referring to the documentation for the ADS-B out device. An ADS-B report should also be requested from the FAA after the airplane has been flown, to further validate the installation.

When connected to a display unit, see the “Status Reporting” section, and verify the GPS is communicating (this also verifies serial communication to the display unit), and verify the power inputs used are showing voltage on these inputs. If this page is grayed out, no communication is being received from the GPS module.

Use the Set Menu, Display Unit Maintenance, and GPS ~~s~~Status (select this GPS if more than one is connected to the EFIS), and verify satellite reception. Typically, at least 7 satellites will show up on the GPS status page. If no, or poor reception, check the antenna connection and verify the antenna has a clear view of the sky.

Data to and from serial ports used on the module combiner are verified by any means that validates serial communication. The technique will vary depending on the device.

Status Reporting

When a serial port has been configured for this module, the status of the module may be observed on the Set Menu, Display Unit Maintenance. In the -GRT Safe-Fly GPS/SPC menu, the following data is provided:

| Name | Description |
|-------------------------|--|
| Module Software Version | Software version of the GPS module |
| GPS Communicating | Yes/No – Indicates if data has been received from the RAIM GPS within the module. Should always show “Yes” when the module is powered. |
| Load Module Software | Select to update the software into the module from a GSPCUp*.dat file. |
| Power Input 1 | Voltage present on this power input |
| Power Input 2 | Voltage present on this power input |
| Power Input 3 | Voltage present on this power input |
| Temperature | Internal temperature of processor |

GPS Specific Status

Detailed data about the performance of the GPS, including the number of satellites being tracked, the signal strengths, etc., is available on the Set Menu, Display Unit, GPS Status. If more than one GPS is connected to the EFIS, be sure to select this GPS.

Approved Devices – Wiring and Configuration

Trig TT21/TT22

Note: All steps in the “Safe-Fly/SPC Configuration” section above must be completed before the following settings are made.

Use of the Safe-Fly GPS for the Trig TT21/TT22 is approved by GRT Avionics when installed and configured as described in this section for experimental category airplanes. This installation meets the requirements of FAR 91-227(c), when wired as shown below, and configured as indicated.

The minimum software versions required are as follows:

| Device | Minimum Software Version |
|------------------------|--------------------------|
| Safe-Fly GPS | 2 |
| Trig Adapter (if used) | 5 |
| Trig TT22 | SW2.7 |

Configuration

| Setting | Required Selection |
|--------------------------|--------------------|
| SPC Serial Port 1 Rate | 38400 |
| SPC Serial Port 1 Output | Safe Fly NN33 |

TT21/TT22 Settings

These can be found in the Set Menu, General Setup, TT22 menu when controlled by the EFIS.

| <u>Setting</u> | <u>Required Selection</u> |
|--------------------------------|---|
| <u>GPS Input</u> | <u>GRT Safe-Fly NN33</u> <u>(select NexNav on non-GRT controllers)</u> |
| <u>GPS/TIS Rate</u> | <u>38400</u> |
| <u>GPS Certification Level</u> | <u>C</u> |
| <u>GPS NACv (m/s)</u> | <u>< 10</u> |

Wiring

| Safe-Fly GPS Pin | Trig TT21/22 Pin | Notes: |
|-------------------|------------------|--|
| 19 – Serial Out 1 | 5 – GPS Input | If the GRT Trig adapter is installed on the TT21/TT22, the connection is made to pin 5 of this adapter. The data will pass through the adapter into the transponder. The adapter software must be version 5 or higher, as reported on the Set menu, General Setup, TrigTT22/EchoUAT menu (near the top of the General Setup settings). |

Post-Installation Checkout - Verifying Trig TT-22 is Receiving GPS Data

When a GPS data stream with a valid position is being received by the TT22, the TT22 reports the received GPS position to the controller. When a GRT EFIS is the controller, this is reported in the Set Menu, General Setup, TT22 page on the GPS Position line. If this line shows a latitude and longitude, the position data is being received from the GPS and will be used for ADS-B out. If this line indicates anything else, the TT22 is not receiving valid position data and will not transmit ADS-B out.

Trig TT31

Note: All steps in the “Safe-Fly/SPC Configuration” section above must be completed before the following settings are made.

Use of the Safe-Fly GPS for the TT31 is approved by GRT Avionics when installed and configured as described in this section for experimental category airplanes. This installation meets the requirements of FAR 91-.227(c), when wired as shown below, and configured as indicated.

The minimum software versions required are:

| Device | Minimum Software Version |
|------------------|--------------------------|
| GRT Safe-Fly GPS | 2 |

Safe-Fly GPS Setting

| Safe Fly GPS Setting | Required Selection |
|--------------------------|--------------------|
| SPC Serial Port 1 Rate | 38400* |
| SPC Serial Port 1 Output | Safe Fly NN33* |

*These are the default settings for the Safe-Fly SPC Serial port 1, so no setup is normally required.

Wiring

| Safe-Fly GPS Pin | Trig TT 21 / 22 31 Pin | Notes: |
|-------------------|--|---|
| 19 – Serial Out 1 | Pin 3 of Secondary Connector – RS232 In 2 | The TT31 must be configured for NexNav GPS In, at 38400 baud. |

TT31 Settings

These settings are made through the Trig TT31 front panel.

| Trig TT33 Setting | Required Selection |
|-------------------------|--------------------------------|
| GPS Input | NexNav on non-GRT controllers) |
| GPS/TIS Rate | 38400 |
| GPS Certification Level | C |
| GPS NACv (m/s) | < 10 |

Other TT31 Considerations

Although the GPS is providing GPS based altitude to the Trig TT31 for its ADS-B output, pressure altitude must also be provided to allow for the mode C altitude encoding output. When the Trig TT31 is used with any GRT EFIS, any serial output from the GRT EFIS can be configured as the altitude encoder output. We recommend using the “Fuel/Air Data (Z Format)”. The baud rate set in the EFIS must match that set in the TT31. According to the Trig TT31 installation manual, RS232 In 1 (on the primary connector) is typically used to receive this data.

Sandia

Note: All steps in the “Safe-Fly/SPC Configuration” section above must be completed before the following settings are made.

Testing is underway to validate the use of the Safe-Fly GPS with the Sandia ADS-B out devices. This manual will be updated when GRT Avionics and Sandia and approved the use of this GPS. We expect this approval soon (second quarter 2017 or sooner).

Uavionix

Note: All steps in the “Safe-Fly/SPC Configuration” section above must be completed before the following settings are made.

Use of the Safe-Fly GPS for the uAvionix EchoUAT is approved for experimental category airplanes by GRT Avionics when installed and configured as described in this section. This installation meets the requirements of FAR 91-227(c).

When the Safe-Fly and EchoUAT are ordered together with the pre-wired cable, no connection to an EFIS is required. Mounting the Safe-Fly/EchoUAT, connecting the antennas, and supplying power via the cable is sufficient to provide UAT out, meet all 2020 compliance, and provide ADS-B weather and traffic data via Wi-Fi to a tablet. ***However, the EchoUAT must be configured as described in the “EchoUAT Settings” section below before the EchoUAT will function as an ADS-B out device.***

Optional connections that allows the GRT EFIS to use the GPS position data, ADS-B weather and traffic, and the serial port combiner features for additional serial ports are also described. These connections also provide the EchoUAT with pressure altitude data from the EFIS (if available).

EchoUAT Settings - (Required)

These settings are accessed via wi-fi using an Android or iphone/ipad and the Echo Install app, in the “Installation” section of the app.

Testing at GRT Avionics showed (as of 6/23/17) some compatibility issues with Android devices using this app. If the app shows "Please connect to PING-XXXX WI-FI Network in Settings" when the phone or tablet has been set to use the “Ping-xxxx” network, you may need to borrow another phone or tablet, or contact uAvionix for technical support. (Note: As of this date we confirmed the app is NOT compatible with Samsung S2, S3, and some LG phones. It was confirmed to work with Samsung S5, Motorola Moto G, and Samsung Galaxy J3 Emerg. This list is incomplete.)

| Setting | Required Setting With EFIS controlling Safe- Fly GPS | Required Settings* No EFIS control of Safe-Fly (Includes WS and HS) |
|-----------------------|---|--|
| Setup Source | EFIS (COM1) | App |
| Control Source | Set to “EFIS / Panel (COM1)” if the squawk code controlled by this display unit, or another GRT display unit connected to this via the inter-display link. Set to “Transponder Monitor” if the squawk code is set on the transponder or otherwise not set by the GRT EFIS. | Transponder Monitor |
| GPS Source | EFIS (COM1) | External GPS (Com2) |
| Traffic/Uplink Output | MFD (COM2) | MFD (Com2) |
| COM1 Rate | 38400 | 38400 |
| COM1 Data | 810 | 810 |
| COM1 PHY | RS-232 | RS-232 |
| COM1 Protocol: | TMAP | TMAP |
| COM2 Rate | 115,200 | 115,200 |
| COM2 PHY | RS-232 | RS-232 |
| COM2 Output Protocol | GDL90 | GDL90 |
| Baro Altitude Source | Not Applicable | Internal |
| COM2 Data | Not Applicable | 81N |
| COM2 Input Protocol | Not Applicable | NMEA |

* Other settings are also required corresponding to airplane specific entries, such as aircraft type, length, width, antenna offset, etc.

EFIS Configuration

The following serial port settings are made from the “Set Menu”, “General Setup”

| Setting | Required Setting With EFIS controlling Safe-Fly GPS | Required Settings No EFIS control of Safe-Fly (Includes WS and HS) |
|---|--|---|
| Flight ID (In Flight ID and Address sub-menu) | Set to aircraft N-number | Not required |
| Mode S Address | Set to Mode S Address (Hex) from FAA registration | Set to Mode S Address (Hex) from FAA registration |
| Serial Port X* In | Safe-Fly GPS and SPC | NMEA0183 GPS |
| Serial Port X* Out | Safe-Fly GPS and SPC | Not Applicable – Not Used |
| Serial Port X* Rate | 115,200 | 9600 |
| SPC Serial Port 1 Rate | 38400 | Not Applicable |
| SPC Serial Port 1 Output | EchoUAT TMAP | Not Applicable |
| SPC Serial Port 1 Input | EchoUAT TMAP | Not Applicable |
| Serial Port Y* In | ADS-B | ADS-B |
| Serial Port Y* Rate | 115,200 | 115,200 |
| TT22/EchoUAT Settings | Required – See below | Not Used |

*Serial port “X” refers to the serial port on the EFIS that is wired to the “Serial Control In/Out” of the Safe-Fly GPS module. Serial port “Y” refers to the serial port used to receive ADS-B data into the EFIS. These will be different serial ports. For example, Serial port “X” could be Serial port 1, and Serial Port “Y” could be Serial port 2 (depending on what serial ports are not already in use and are high-speed in your EFIS will determine the serial ports you can use.)

EFIS Configuration - TT22/EchoUAT Settings

After the serial port has been configured per the above paragraph, and serial communication with the Safe-Fly has been confirmed by noting the serial port counter is counting for the serial port X (the serial port configured for, and wired to the Safe-Fly GPS control input/output), then the following settings must be made. These settings are made from the TT22/EchoUAT page which is accessed from the Set Menu, General Setup, and will be near the top of this page. Use the “Change to activate menu” selection to show the TT22/EchoUAT page. Set at least the following items in these pages:

| Setting/Status | Value |
|------------------------------|--------------|
| DU-SF Communication (Status) | Verify “Yes” |

| | |
|---------------------------------|--|
| SF-echoUAT Communication | Verify “OK” |
| Remote Status | Verify “OK” |
| External GPS Communication | Verify “Yes” |
| Squat Switch | Set to “None” |
| Aircraft Category | Set as required, such as “Light Fixed Wing” |
| Speed Category | Set as Required |
| Aircraft Width (m) | Set as required in meters (divide wingspan in feet by 3 to enter as meters) |
| Aircraft Length (m) | Set as required in meters (divide length in feet by 3 to enter as meters) |
| VFR ID | Set to airplane N-number |
| GPS Input* | Compliant TMAP |
| GPS/TIS Rate | Does not apply to EchoUAT |
| GPS Certification Level* | A or B |
| TEST Squitters | Not used |
| TIS Output | Not used |
| UAT/978 Receiver in Aircraft | Set to “Yes” |
| 1090-ES Receiver in Aircraft | Set to “Yes” |
| GPS Antenna Offset: Linear (m) | Set in to distance antenna is from nose of airplane in meters (feet divided by 3). |
| GPS Antenna Offset: Lateral (m) | Set in to distance antenna is from centerline airplane in meters (feet divided by 3) |
| GPS NAC _v * | <10 |
| Mode | Verify “On” |
| Last Reply Count | Reading does not matter |
| GPS Position | Should show position if valid GPS position available |
| Transponder Versions | Reading does not matter |
| Adapter Software Version | Reading does not matter |

*These settings are required to allow the EchoUAT to transmit your data.

Required Safe-Fly software version

The software version for the Safe-Fly GPS, when used with the Uavionix EchoUAT, must be 2.0 or later. Minimum EFIS display unit software is as follows:

| EFIS | Minimum Software Version |
|-------------------------|---------------------------------|
| All models of Mini EFIS | 4.00 |
| Sport EX/Horizon EX | 2.00 |
| Sport SX | 14.00 |
| HX | 10.00 |
| HXr | 6.00 |
| Sport or Horizon WS* | Any |
| Sport or Horizon HS* | Any |

Wiring – GRT SafeFly to EchoUAT for Current GRT EFIS Models

This section applies to the following models: Sport SX, Sport EX, Horizon EX, Horizon HX, Horizon HXR, and all models of the Mini.

For Sport WS, Sport HS, Horizon WS, and Horizon HS, see “Wiring – GRT SafeFly to EchoUAT with no EFIS control” section below, following this section.

The following figure illustrates the wiring to the Safe-Fly GPS and EchoUAT, when used with a GRT EFIS configured to control the Safe-Fly GPS via the serial control In/Out on the Safe-Fly GPS. This wiring cannot be used with Sport or Horizon HS and WS models.

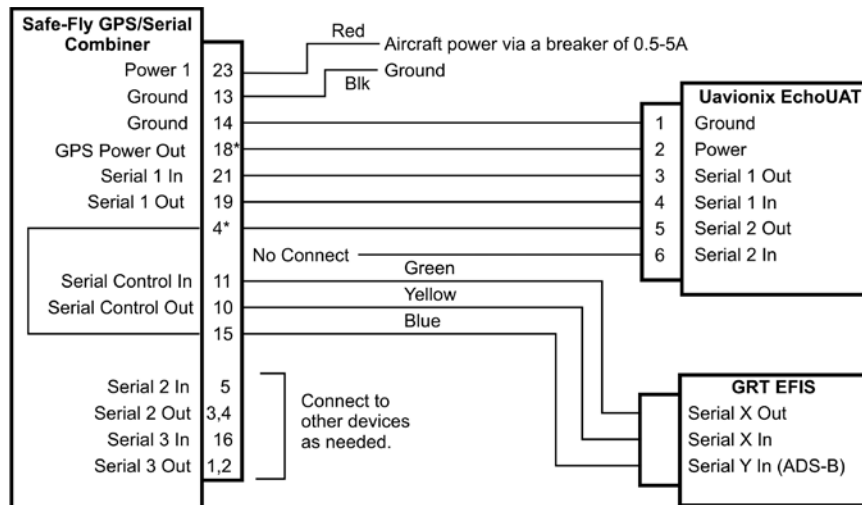

*For Safe-Fly Rev A (may not be indicated on the label, shipped prior to April 2017), does not support these connections. Connect EchoUAT pin 2 to aircraft power, and pin 5 directly to EFIS serial input.

Safe-Fly to EchoUAT Pre-Wired Cable

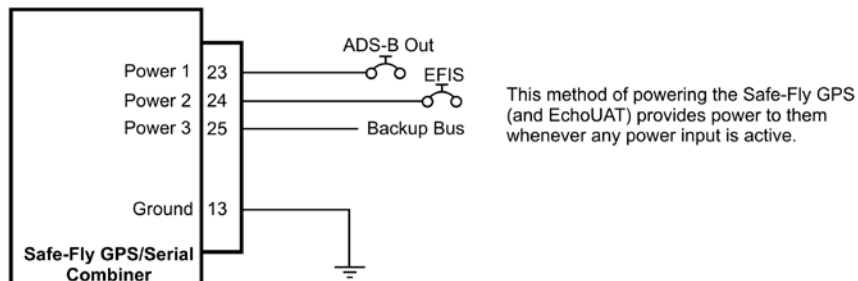

Safe Fly to EchoUAT wiring diagram Rev D.cdr

Typical use of multiple power inputs

Wiring – GRT SafeFly to EchoUAT with no EFIS control (Including Sport and Horizon WS and HS Models)

The following figure illustrates the wiring to the Safe-Fly GPS and EchoUAT, when no EFIS exists, or the EFIS is unable to control the GPS, such as the Sport and Horizon HS and WS models.

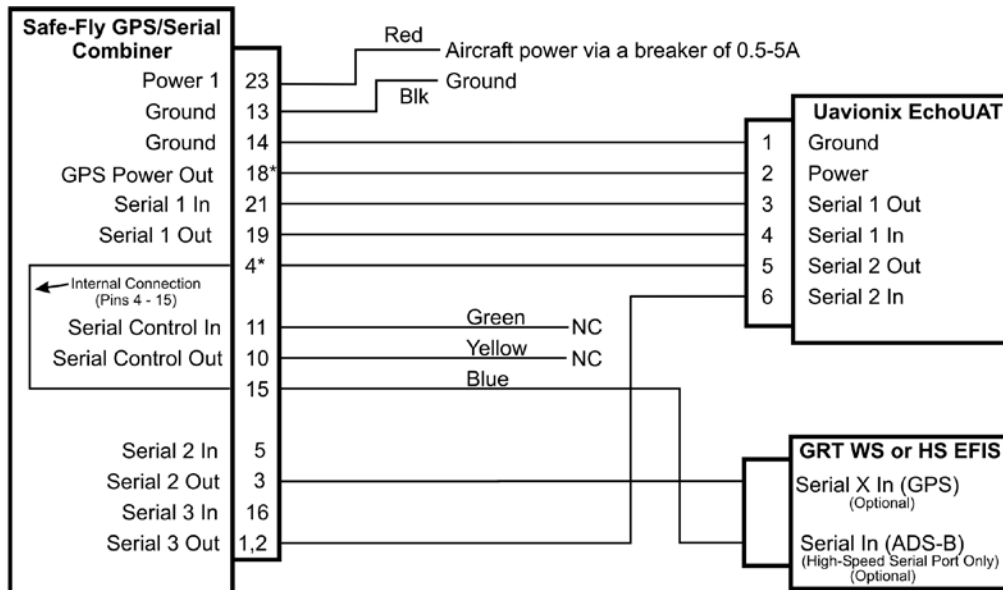

*Rev A Safe-Fly, identified with red on label, does not support these connections.

The blue wire must connect to the high-speed serial input, (serial port 4 for HS and WS models) to display ADS-B weather and traffic data.

See Text for required settings.

Safe-Fly to EchoUAT Pre-Wired Cable to HS or WS GRT EFIS

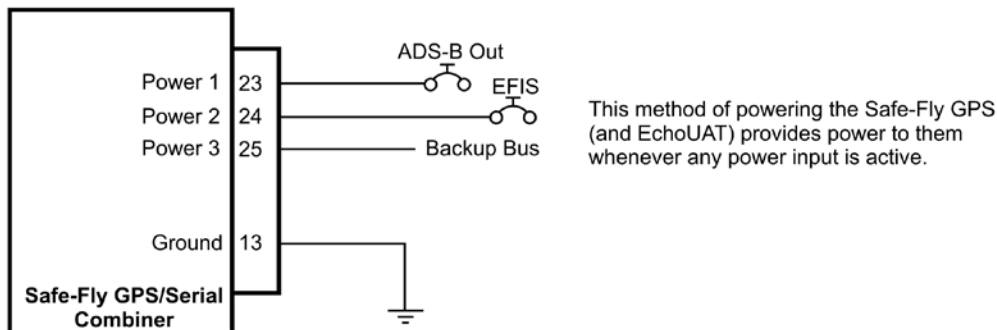

Safe Fly to EchoUAT wiring diagram - for HS and WS.cdr

Typical use of multiple power inputs

Post-Installation Verification

The following post-installation checkout procedure should be used to validate normal operation of this equipment after installation. This procedure requires that power is supplied to the equipment.

1. Using the Echo app, select “Monitor” at the top of the app. This will show the Address, call sign, and other data, including Latitude and Longitude. Verify the Latitude and Longitude fields are not dashes (actual latitude and longitude should be displayed. This confirms the EchoUAT is communicating successfully with the Safe-Fly.
2. Refer to the “Status Reporting” section above to verify serial communication is functioning between the EFIS and Safefly control input/output, power connections, and Safe-Fly software version.
3. If ADS-B data is provided to the EFIS via a serial connection, verify the serial data counter is counting on the Set Menu, General setup, for the serial port used to receive this data. When in flight, reception of ADS-B data can be verified on the Set Menu, Display Unit Maintenance, under the ADS-B status setting. Valid frame should be detected. Alternatively, when in-flight and in range of an ADS-B ground station, METARs data will be observed when reviewing airport details.
4. If the Safe-Fly is connected to the EFIS, detailed data about the performance of the GPS, including the number of satellites being tracked, the signal strengths, etc., is available on the Set Menu, Display Unit, GPS Status. If more than one GPS is connected to the EFIS, be sure to select this GPS. Other than the first few minutes after power-up, RAIM integrity should be provided and at least 6 satellites should be used in the calculations. If this is not observed, check the antenna connection and verify the antenna has a clear view of the sky.

Specifications

- Power Requirements: 9-32Vdc, 0.2 Amp maximum
- Weight: 0.4 lbs
- Mounting Orientation: Any

GPS Specifications:

- GPS Type: 12-channel -GPS satellite receiver using GPS constellation and satellite-based augmentation system (SBAS), such as WAAS, EGNOS, MSAS and GAGAN to the extent of WAAS compatibility.
- Approvals: Certified by GRT Avionics to FAR 91.227 when used with a ADS-B out device in the “Approved Devices” section. GPS sensor meets TSO-C199, Appendix 1, Section A1.2.6 and FAR Section 91.227(c) for ADS-B out.

| NMEA0183 Sentences Transmitted |
|--------------------------------|
| \$GPGGA |
| \$GPGLL |
| \$GPGSA |
| \$GPGSV |
| \$GPRMC |
| \$GPVTG |
| \$GPZDA |
| \$RAIM (proprietary) |

Serial Combiner Specifications:

- User configurable serial ports: 3
- Available buad rates: 110, 300, 600, 1200, 2400, 4800, 9600, ~~14400~~, 19200, 38400, ~~56000~~, 57600, 115200
- Available Serial Port Functions: All serial port functions available on the display unit can be used through the combiner, as well as ADS-B specific GPS outputs.

Connector Pinout

Safe-Fly 2020 ADS-B Compliant GPS Pinout Hardware Version Rev. B

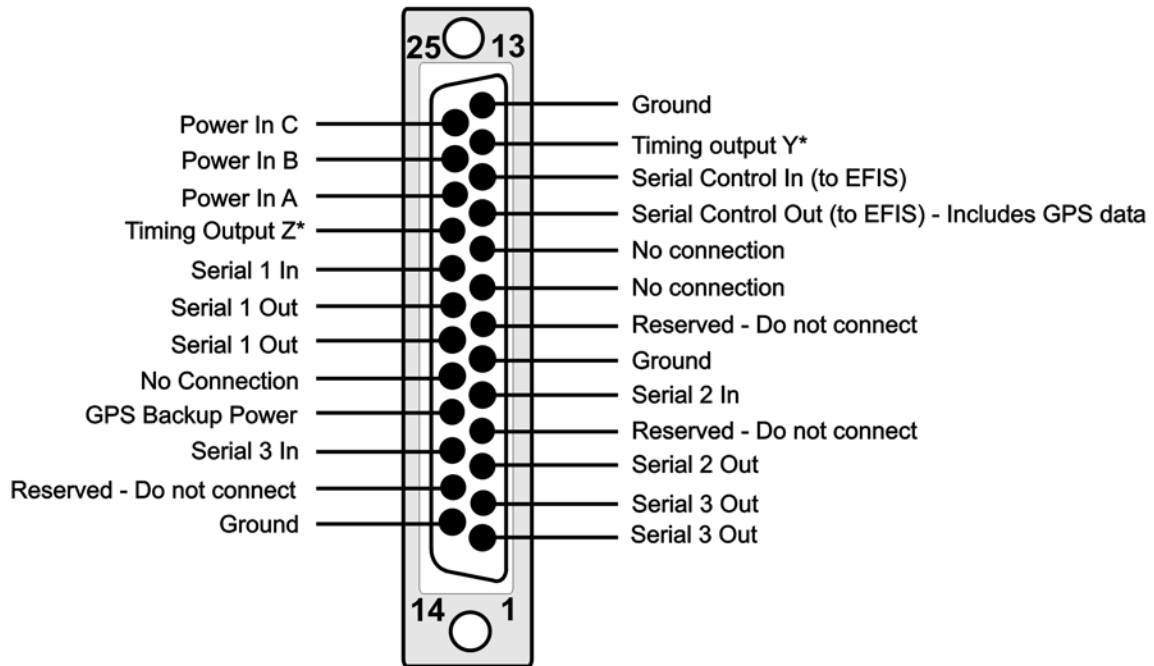

Rear View of Connector Housing

This view shows the side of the connector housing that the wire are inserted into.

Male d-sub connector. (GPS unit has female d-sub connector.)

This is a male d-sub connector. It can be identified by its hollow end opposite the side the wires are installed. The contacts for this connector are male pins.

Safe-fly pinout Rev B Hardware.cdr

Dimensions

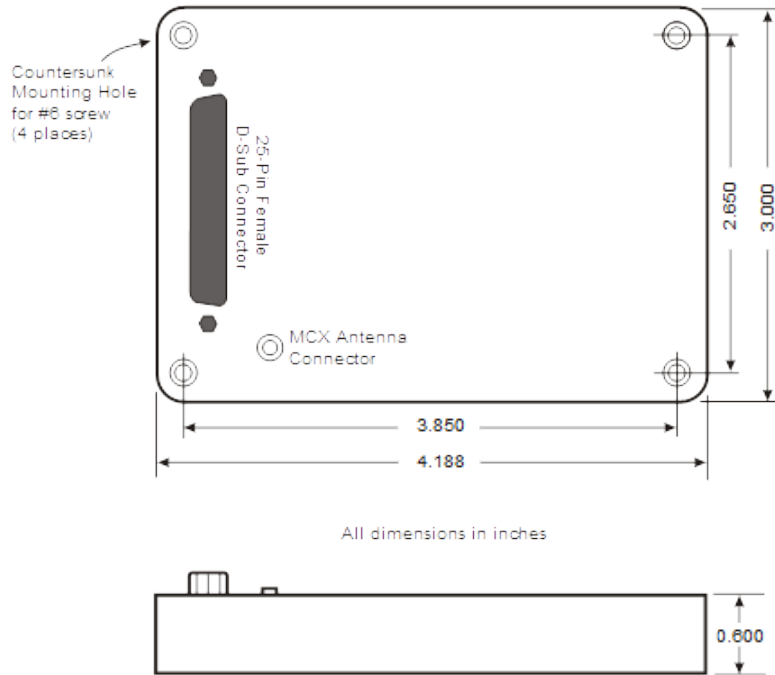

Notes:

1. Mount in a location to avoid exposure to water and excessive heat, such as from cabin heat ducts.
2. No cooling required.
3. Secure with 2 or more mounting screws in opposite corners.
4. See user manual for wiring.

Safe-Fly 2020 ADS-B Compliant GPS Module/Serial Port Combiner



Typical Wiring

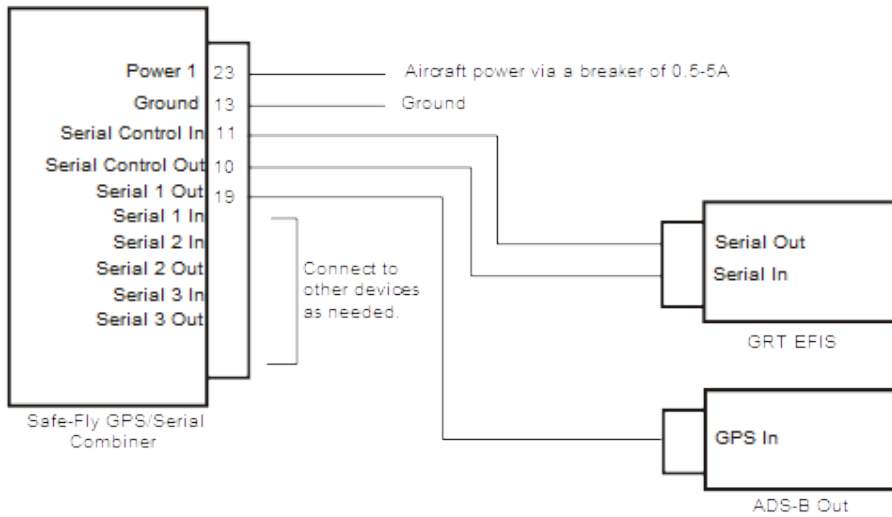

Typical wiring

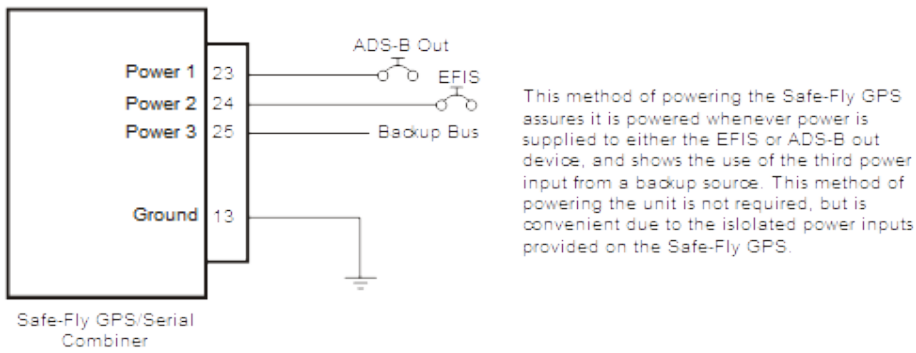

Typical use of multiple power inputs

Included Cable Assembly

The cable assembly is provided with a 25-pin male d-sub connector, housing, backshell, and a variety of wires pre-pinned with male contacts ready for insertion into the d-sub housing. In addition, 10 d-sub male contacts are provided. All wires for the adapter are 4' long, but can be replaced with longer wires as needed. When inserting the wires into the housing, be sure to insert them into the correct holes, as removing them requires a pin extraction tool, and can be difficult.

| Wire Color | Suggested Function |
|-------------------|---------------------------|
| Red | Power 1 |
| Black | Ground |
| White | Any |
| Blue | Any |
| Orange | Any |
| Yellow | Any |
| Green | Any |
| Violet | Any |
| White/Green | Serial Control In |
| White/Blue | Serial Control Out |