

MFD 1

GNC 300XL

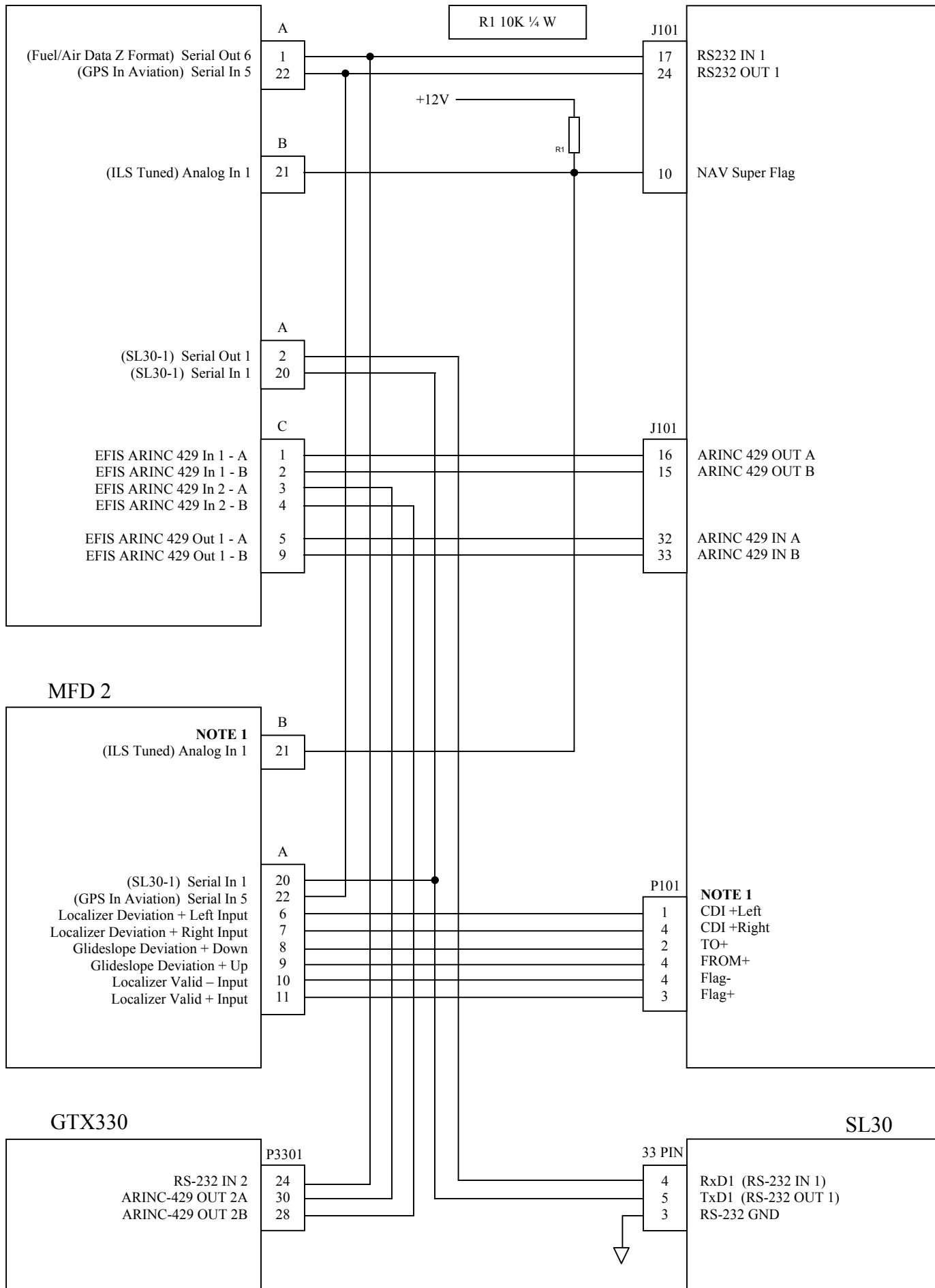

NOTE 1 : These connections are for redundancy in case of loss of MFD 1, normally supplied from inter display communications.

Document Version History

WD-1004-01 First released version.

WD-1004-02 Corrected file name and date from WD-1001-04 to WD-1004-02.
Changed R4 to R1 and added value.
Added missing connection for ARINC-429 from MFD-C-9 to
300XL-J101-33